



Our main ingredient is value

MG0012

MADE IN THE USA

MG0012

MEAT & FOOD GRINDER

NEW! GEAR DRIVEN, 1/2 H.P. MOTOR

Designed for small volume use. The MG0012 is a rugged performer, yet compact and portable. Driven by a 1/2 H.P. motor and a sturdy gearbox, our MG0012 is tough but quiet. Perfect for hunters. It also grinds ginger root. Standard equipment includes a grinder attachment with 3/16" plate, X-knife (no.12), deep stainless steel feed pan and poly stomper. As with all Univex products the MG0012 is engineered with maximum price/value for years of trouble-free performance. This unit is UL listed.

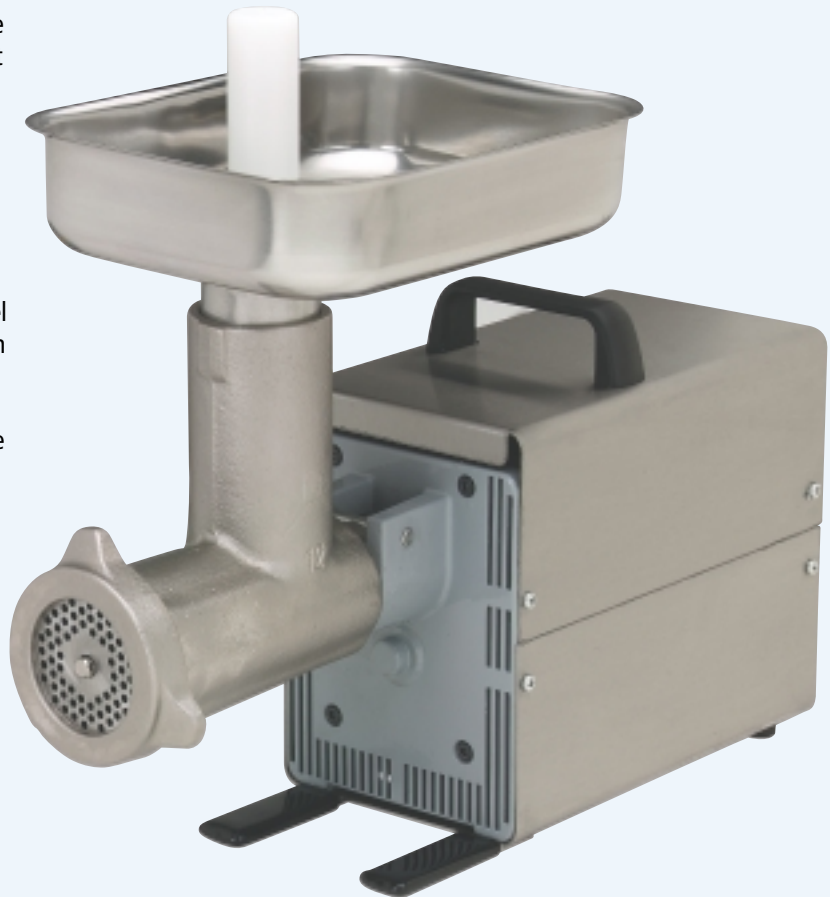

WARRANTY

Model MG0012 Meat & Food Grinder carries a 6-month carry-in warranty on parts against any flaws in materials and workmanship. This period begins with the date of purchase and, provided the unit is used properly in accordance with our instructions, is in full effect for one year from that date. Any work to be performed under this warranty must be performed between the hours of 8:00 a.m. and 5:00 p.m. local time, Monday through Friday. Univex will not pay overtime charges for work performed other than during normal business hours. Damages incurred in transit or from installation error, accident, alteration or misuse are not covered. Transit damages should be reported to the carrier immediately. Univex shall not be liable for any consequential, compensatory, incidental, or special damages. Contact Univex Service Department for any warranty claims.



UNIVEX CORPORATION ■ 3 Old Rockingham Road ■ Salem, NH 03079-2140
Tel 603-893-6191 ■ Fax 603-893-1249 ■ E-mail univex@univexcorp.com
TOLL-FREE ORDERING FAX 1-800-356-5614
www.univexcorp.com

April 2005
Printed in USA

MEAT AND FOOD GRINDER

MG0012

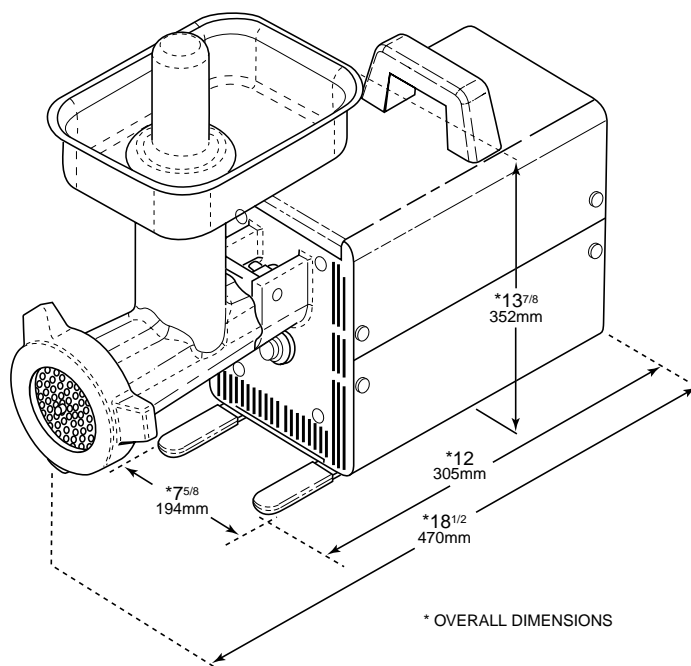

SPECIFICATIONS

| | |
|---------------------------|---|
| ELECTRICAL: | 115V, 60Hz, Single Phase. Consult factory for special voltages. |
| MOTOR: | 1/2 HP Capacitor start 3360 RPM |
| DRIVE: | 24:1 Reduction produces high torque through a rugged gear box. 140 RPM drive shaft. |
| DRIVE ASSEMBLY: | Completely enclosed in a 20 gauge stainless steel cover with a painted cast aluminum front panel. |
| SWITCH: | Toggle type double pole on-off conveniently located on left side of machine. |
| CORD & PLUG: | 5 ft. (1524mm) long, 3-wire 16 gauge SJTO cord with polarized molded plug. (NEMA 5-15P). |
| MEAT GRINDER: | Electroless nickel plated cast iron housing with No. 12 knife and plate. All parts are easy to remove for cleaning. |
| FEED PAN: | 3 1/4 qt. (3 ltr.) capacity, 7 1/2" x 20" x 2 1/2" (190 x 254 x 64mm), Stainless Steel. |
| STORAGE CONTAINER: | 18 1/2" x 13 1/2" (470 x 343mm) plastic |
| FEED STOMPER: | High density polyethylene stomper designed for ease of handling and operator safety. |
| CAPACITY: | 4-6 lbs (2-3kg) per minute on first grind using a plate with 3/16" (4mm) holes. |
| WEIGHT: | Net 28 lbs (13kg), Shipping 30 lbs (14kg). |
| BOX DIMENSIONS: | 14" W x 18" L x 13"H (356 x 457 x 330mm) |
| CUBE: | 1.9 cu ft, (0.05 cu m) |



UNIVEX CORPORATION ■ 3 Old Rockingham Road ■ Salem, NH 03079-2140
 Tel 603-893-6191 ■ Fax 603-893-1249 ■ E-mail univex@univexcorp.com
 TOLL-FREE ORDERING FAX 1-800-356-5614
www.univexcorp.com